

# Speedmatic Easy Master

Driver for one single-phase or 3-phase pump with variable speed. Plug and play unit.

General electric supply is single-phase 230 Vac. Easy to setup and operate, as it's only necessary to connect and select the setpoint pressure. It can be mounted individually (only one pump) or in group of 2 pumps communicated and operating in MASTER-SLAVE mode with alternated sequence of operation.

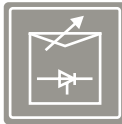

**EASY 09 MM**

**EASY 12 MM**

**EASY 06 MT**

**EASY 10 MT**



## OPERATING CHARACTERISTICS

- Pump managed by frequency converter (inverter).
- ART function (Automatic Reset Test). If the device has been stopped due to the action of the safety system against dry operation, the ART tries to connect the pump, with a programmed periodicity because the water supply could have been restored.
- Possibility of being mounted next to another identical device operating in mode MASTER-SLAVE. The group will be formed by a main device configured like MASTER and the rest of devices configured like SLAVES. The operating system is alternated, the device configured as MASTER is the responsible of the control but it does not imply that is first in starting up when there is flow demand in the network.
- Automatic restore system after an interruption of power supply. System restores the previous mode keeping the configuration parameters.
- Inner pressure transducer with digital indicator,
- Inner current sensor with instantaneous digital reading.
- Control and information panel with 2 digits.
- Register of operational controls. Information about: operating hours, counter of starts, counter of connections to the power supply.
- Register of alarms. Information about type and number of alarms since the starting up of the device.
- Open PID in the expert menu.

## TECHNICAL CHARACTERISTICS

	09MM	12MM	06MT	10MT
Power supply voltage	~1 x230 Vac	~1 x230 Vac	~1 x230 Vac	~1 x230 Vac
Frequency	50/60 Hz	50/60 Hz	50/60 Hz	50/60 Hz
Output	~1 x230 Vac	~1 x230 Vac	~3 x230 Vac	~3 x230 Vac
Max. current	9 A	12 A	6 A	10 A
Max. peak of current	20% 10"	20% 10"	20% 10"	20% 10"
Range of set pressure	0,5 ÷ 8 bar	0,5 ÷ 8 bar	0,5 ÷ 8 bar	0,5 ÷ 8 bar
Protection degree.	IP55	IP55	IP55	IP55
Max water temperature.	40 °C	40 °C	40 °C	40 °C
Max environment temperature.	50 °C	50 °C	50 °C	50 °C
Net weight (without cables)	2,5 kg	2,5 kg	2,5 kg	2,5 kg
Innet and outlet threads	G 1 1/4"M	G 1 1/4"M	G 1 1/4"M	G 1 1/4"M
Max flow	10.000 l/h	10.000 l/h	10.000 l/h	10.000 l/h
	i/o: ~1/~1		i/o: ~1/~3	

## CONTROL PANEL

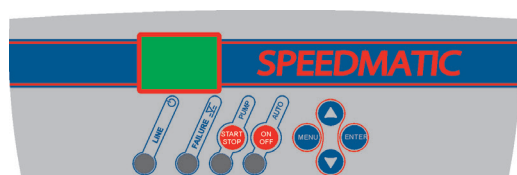

Control panel includes LCD screen, warning leds, push-buttons, START-STOP, AUTOMATIC and configuration system.

## SAFETY SYSTEMS

- Control and safety against overload.
- Control and safety system against wrong supply voltage.
- Control and safety system against short-circuit.
- Control and safety system against dry-running operation.

## DIMENSIONS

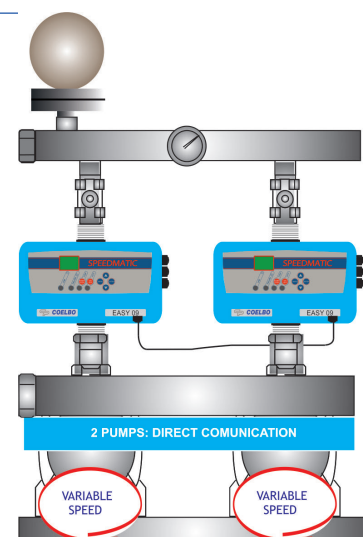
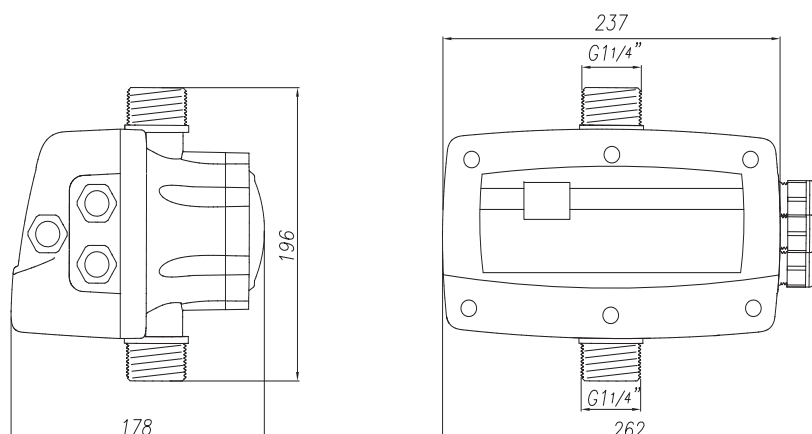

Coelbo Pump drivers